

**NOTICE**

THIS DOCUMENT CONTAINS INFORMATION WHICH IS BOTH CONFIDENTIAL AND PROPRIETARY TO CAPSTONE TURBINE CORP. NEITHER THIS DOCUMENT NOR THE INFORMATION CONTAINED HEREIN SHALL BE COPIED, DISCLOSED TO OTHERS OR USED FOR ANY PURPOSES BEYOND THE SPECIFIC PURPOSE FOR WHICH THIS DOCUMENT WAS DELIVERED WITHOUT THE EXPRESS WRITTEN PERMISSION OF CAPSTONE TURBINE CORPORATION.  
1888 CAPSTONE TURBINE CORPORATION - ALL RIGHTS RESERVED

- NOTES**
- 1 INTERPRET DRAWING PER ASME Y14.5M-1994.
  - 2 ALL DIMENSIONS ARE IN INCHES [MILLIMETERS]
  - 3 ALL DIMENSIONS ARE NOMINAL & ARE TO BE USED AS REFERENCE FOR BUILDING ONLY, UNLESS OTHERWISE SPECIFIED ON THE DRAWING.
  - 4 ALL AROUND CLEARANCES SHOULD BE PROVIDED FOR SERVICE ACCESS. ADDITIONAL SERVICE CLEARANCE WILL BE REQUIRED IF USING A FORKLIFT, SERVICE CART, ETC DURING MAINTENANCE.
  - 5 ISO 1611 COMPATIBLE CORNER FITTINGS.
  - 6 MOUNT LEVEL WITHIN 2% GRADE, SURFACE MUST DRAIN TO PREVENT STANDING WATER. CONCRETE FOUNDATION MUST BE BUILT TO FF/FL OF FF50/FL33 FOR SPECIFIED OVERALL VALUE AND FF25/FL17 FOR LOCAL MINIMUM VALUE. SEE ACI SPEC ACI 302 FOR FURTHER DETAILS.
  - 7 FORKLIFT, SPREADER BARS, PALLET JACK, ETC., MAY BE USED FOR LIFTING UNIT FROM EITHER SIDE.
  - 8 PROPER RIGGING TO BE PROVIDED DURING LIFTING FOR STABILITY OF THE UNIT. IF LIFTING AT CORNER CASTINGS, SPREADER BARS ARE REQUIRED. WHEN LIFTED USING FORK POCKETS, SUPPORT MUST BE PROVIDED ALL THE WAY THROUGH.
  - 9 SPREADER BAR/BEAM, I-BEAM/PIPE, CHAINS AND LIFTING DESIGN NOT BY CAPSTONE.
  - 10 REFER TO PRODUCT CATALOG FOR OPTIONAL ACCESSORIES.
  - 11 C1000 CONTROLLER WIRING IS CLASS #2 AND FIELD WIRING TO BE CLASS #1.
  - 12 HIGH POWER USER CONNECTION SUITABLE FOR USE WITH EITHER COPPER OR ALUMINUM CONDUCTORS.
  - 13 BOLD DIMENSIONS INDICATE THE MAXIMUM WIDTH, HEIGHT OR DEPTH.
  - 14 ALL VIEWS SHOW GASEOUS FUEL CONNECTION UNLESS OTHERWISE STATED.
  - 15 INTAKE HOOD MUST BE REMOVED WHEN LIFTING AND TRANSPORTING.

REVISIONS			
LTR	DESCRIPTION	DATE	APPROVED
A	PER ECO 105511	11/23/15	P. BREault
B	PER ECO 105575	03/07/16	P. BREault
C	PER ECO 105731	03/07/17	P. BREault

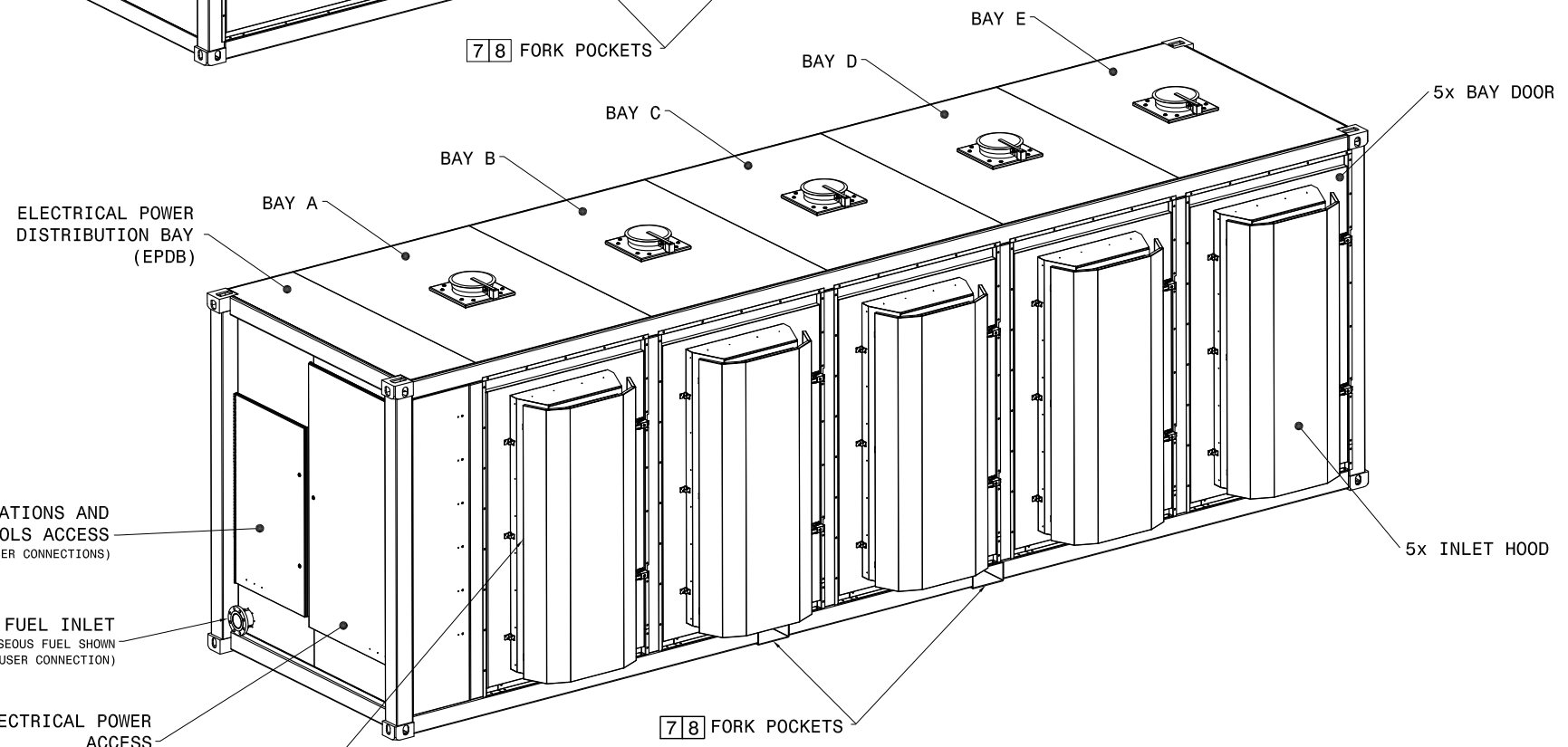
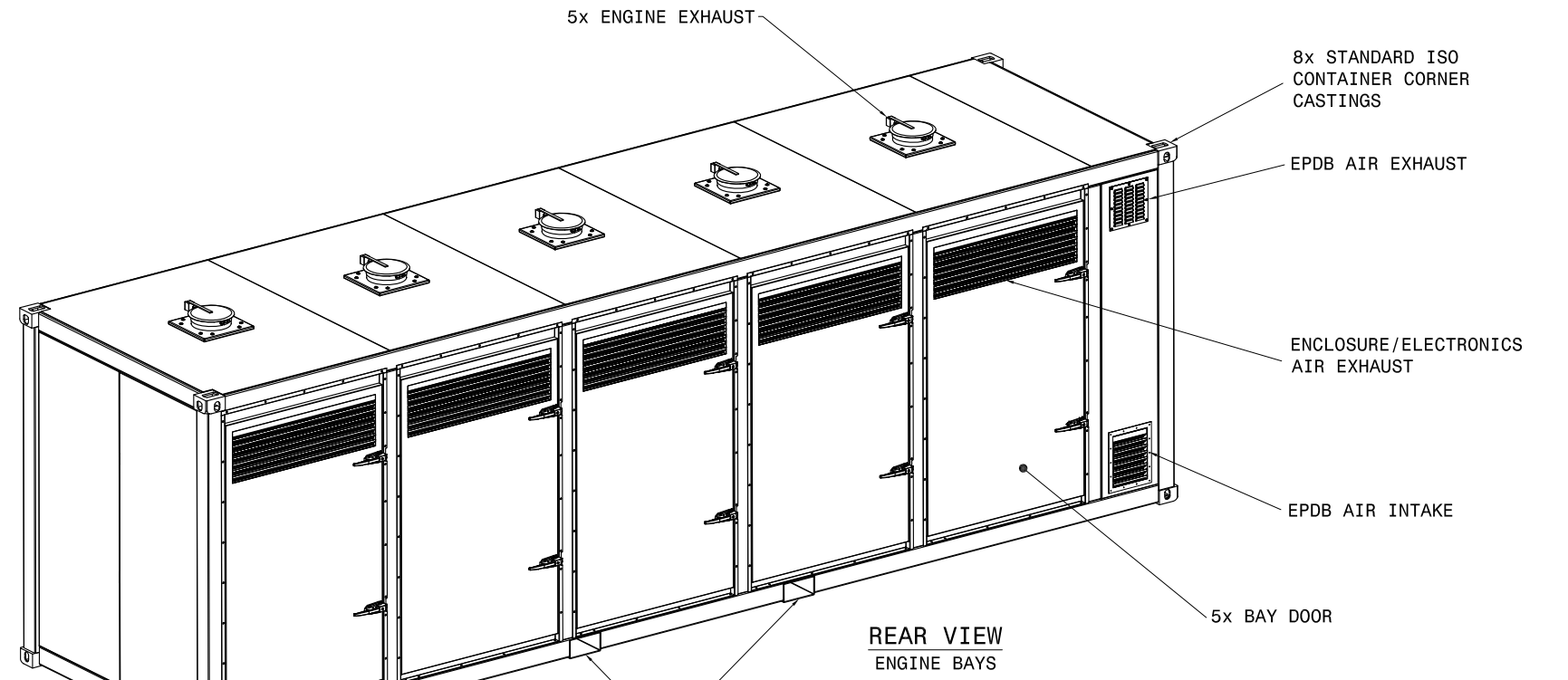

STANDARD WEIGHTS			
C1000			
HPNG/HPSPG	DUAL MODE	45,500 LBS	20,650 KG
LPG/A/B	GRID CONNECT	37,700 LBS	17,100 KG
C800 (FIVE BAY PKG)			
HPNG/HPSPG	DUAL MODE	39,700 LBS	18,000 KG
LPG/A/B	GRID CONNECT	33,500 LBS	15,200 KG
C600 (FIVE BAY PKG)			
HPNG/HPSPG	DUAL MODE	33,900 LBS	15,400 KG
LPG/A/B	GRID CONNECT	29,300 LBS	13,300 KG
C800 (FIVE BAY)			
HPNG/HPSPG	DUAL MODE	48,500 LBS	22,000 KG
LPG/LF	GRID CONNECT	40,700 LBS	18,500 KG
C600 (FIVE BAY)			
HPNG/HPSPG	DUAL MODE	42,100 LBS	19,100 KG
LPG/LF	GRID CONNECT	35,900 LBS	16,300 KG
C1000			
HPNG/HPSPG	DUAL MODE	39,700 LBS	18,000 KG
LPG/A/B	GRID CONNECT	33,500 LBS	15,200 KG
C800 (FIVE BAY)			
HPNG/HPSPG	DUAL MODE	35,800 LBS	16,250 KG
LPG/LF	GRID CONNECT	31,100 LBS	14,100 KG

CONFIGURATION MINUS BATTERY WEIGHTS			
C1000			
HPNG/HPSPG	DUAL MODE	38,700 LBS	17,550 KG
LPG/A/B	DUAL MODE	41,700 LBS	18,900 KG
C800 (FIVE BAY)			
HPNG/HPSPG	DUAL MODE	34,300 LBS	15,550 KG
LPG/A/B	DUAL MODE	36,700 LBS	16,650 KG
C600 (FIVE BAY)			
HPNG/HPSPG	DUAL MODE	29,900 LBS	13,550 KG
LPG/LF	DUAL MODE	31,700 LBS	14,350 KG

FUELS	FUEL INLET	MODES	
		DM	GC
LPNG	4" FLANGE	X	X
HPNG	4" FLANGE	X	X
LPG	4" FLANGE	X	X
LANDFILL (TYPE A)	4" FLANGE	-	X
DIGESTER (TYPE B)	4" FLANGE	X	X
LIQUID	SEE DETAIL A	X	X

UNLESS OTHERWISE SPECIFIED DIMENSIONS ARE IN INCHES TOLERANCES ARE:	APPROVALS	DATE	2111 HORDOFF STREET DARTMOUTH, GA 31511
DECIMALS .XX ±.02 ANGLES .XXX ±.010 ±.5°	DFR P. BREault 03/08/17 DWR S. ALDER 03/08/17 EDR G. TERZER 03/09/17 COB EVO P. BREault 03/09/17 SEAT EVO	TITLE <b>O&amp;I, C1000S SERIES, IND PKG</b>	
MATERIAL	THIRD ANGLE PROJECTION	SIZE D SCALE NONE	DWG NO. 1U1M9 534054-001 REV. C

COPY IS UNCONTROLLED; USER IS RESPONSIBLE TO VERIFY CURRENT REVISION

**NOTICE**

THIS DOCUMENT CONTAINS INFORMATION WHICH IS BOTH CONFIDENTIAL AND PROPRIETARY TO CAPSTONE TURBINE CORP. NEITHER THIS DOCUMENT NOR THE INFORMATION CONTAINED HEREIN SHALL BE COPIED, DISCLOSED TO OTHERS OR USED FOR ANY PURPOSES BEYOND THE SPECIFIC PURPOSE FOR WHICH THIS DOCUMENT WAS DELIVERED WITHOUT THE EXPRESS WRITTEN PERMISSION OF CAPSTONE TURBINE CORPORATION.  
 1885 CAPSTONE TURBINE CORPORATION - ALL RIGHTS RESERVED

REVISIONS			
LTR	DESCRIPTION	DATE	APPROVED
SEE SHEET 1			

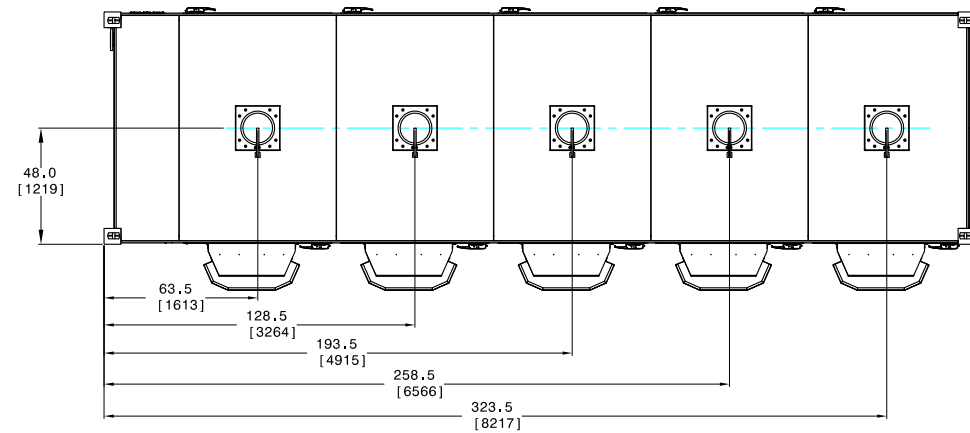

**TOP VIEW**

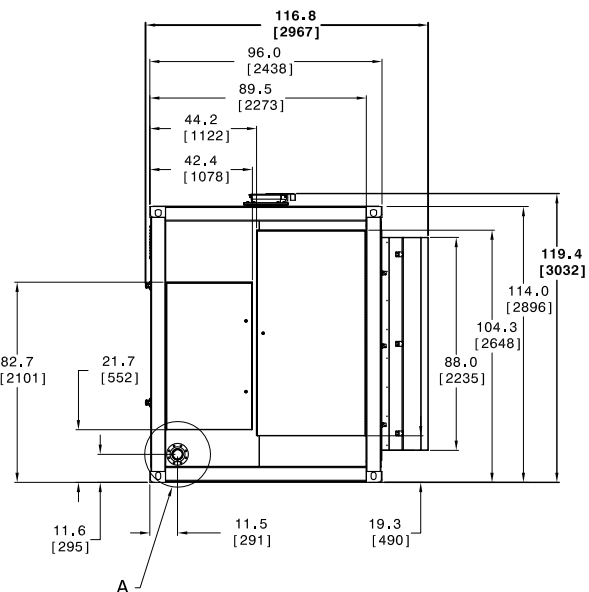

**SIDE VIEW  
CONNECTION BAYS  
(GASEOUS FUEL SHOWN)**

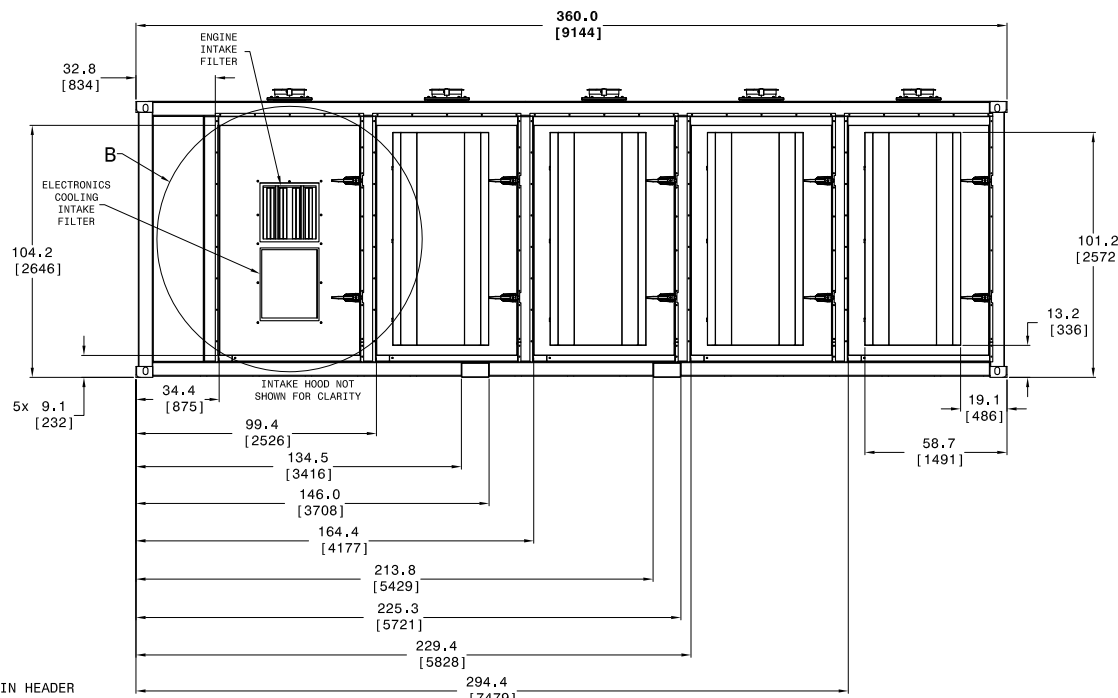

**FRONT VIEW**

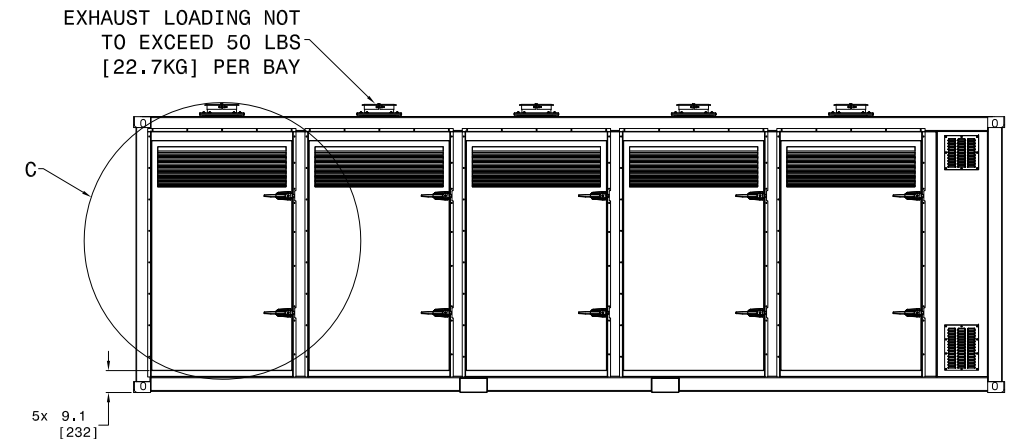

**REAR VIEW**

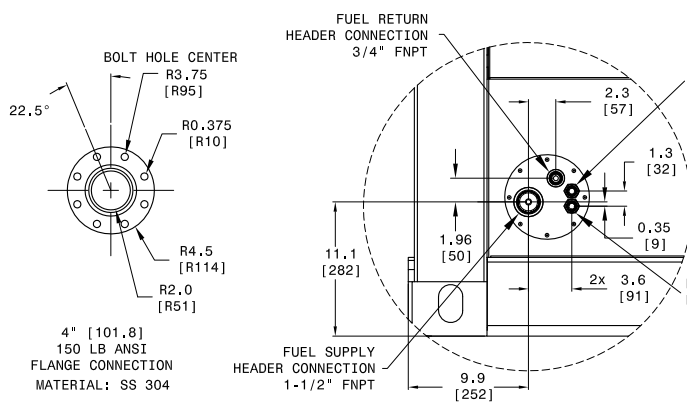

**DETAIL A  
INLET FLANGE**

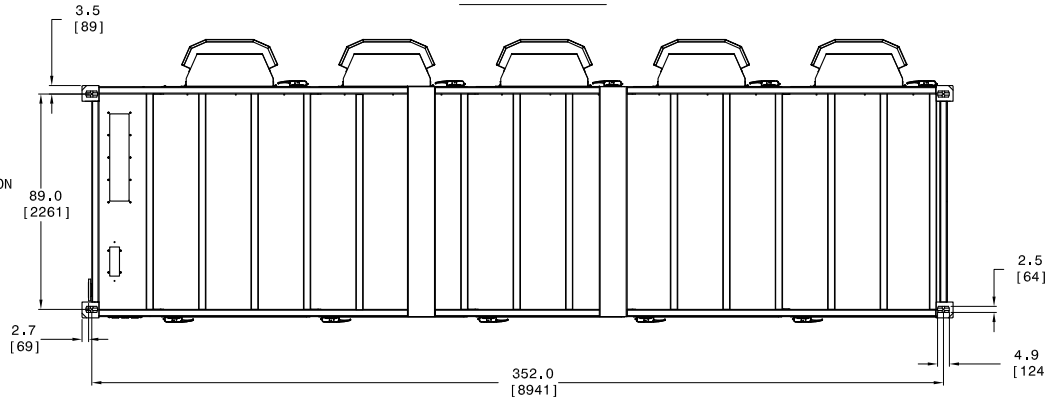

**BOTTOM VIEW**

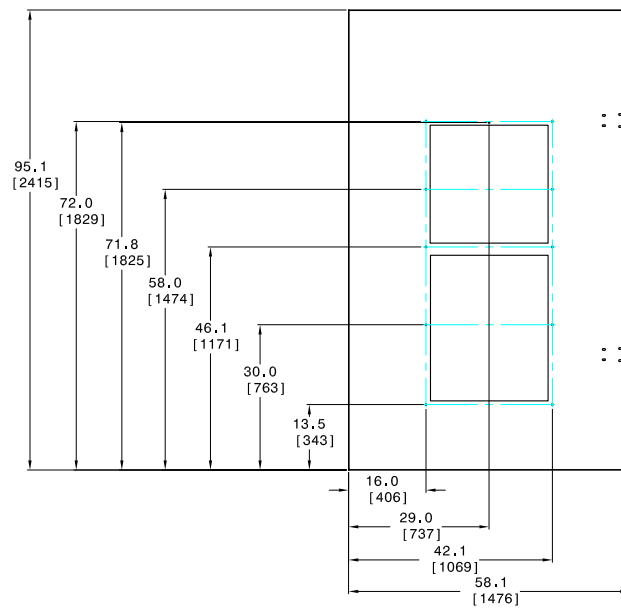

**DETAIL B  
FRONT DOOR  
(SCALE 2:1)**

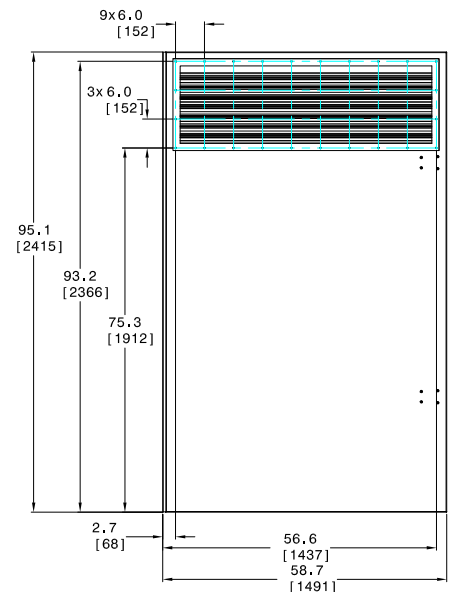

**DETAIL C  
REAR DOOR  
(SCALE 2:1)**

**NOTICE**

THIS DOCUMENT CONTAINS INFORMATION WHICH IS BOTH CONFIDENTIAL AND PROPRIETARY TO CAPSTONE TURBINE CORP. NEITHER THIS DOCUMENT NOR THE INFORMATION CONTAINED HEREIN SHALL BE COPIED, DISCLOSED TO OTHERS OR USED FOR ANY PURPOSES BEYOND THE SPECIFIC PURPOSE FOR WHICH THIS DOCUMENT WAS DELIVERED WITHOUT THE EXPRESS WRITTEN PERMISSION OF CAPSTONE TURBINE CORPORATION.  
1995 CAPSTONE TURBINE CORPORATION - ALL RIGHTS RESERVED

REVISIONS			
LTR	DESCRIPTION	DATE	APPROVED
	SEE SHEET 1		

**CENTER OF GRAVITY TABLE**

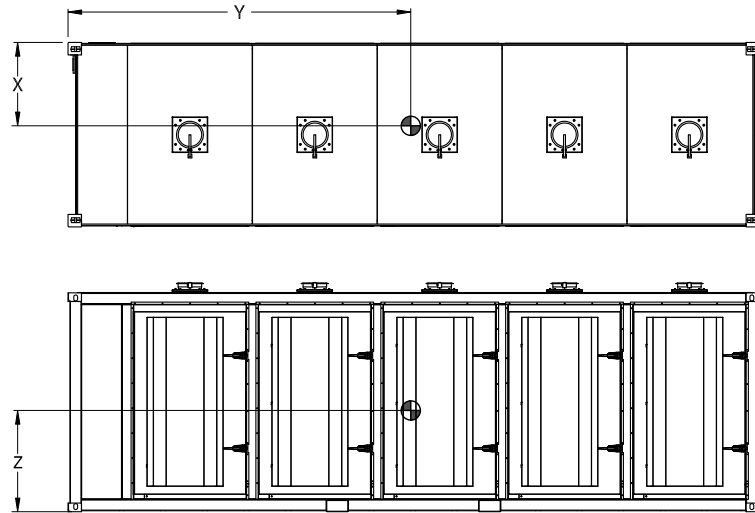

**ELECTRICAL CONNECTION ACCESS**  
USER CONNECTION ACCESS PANELS

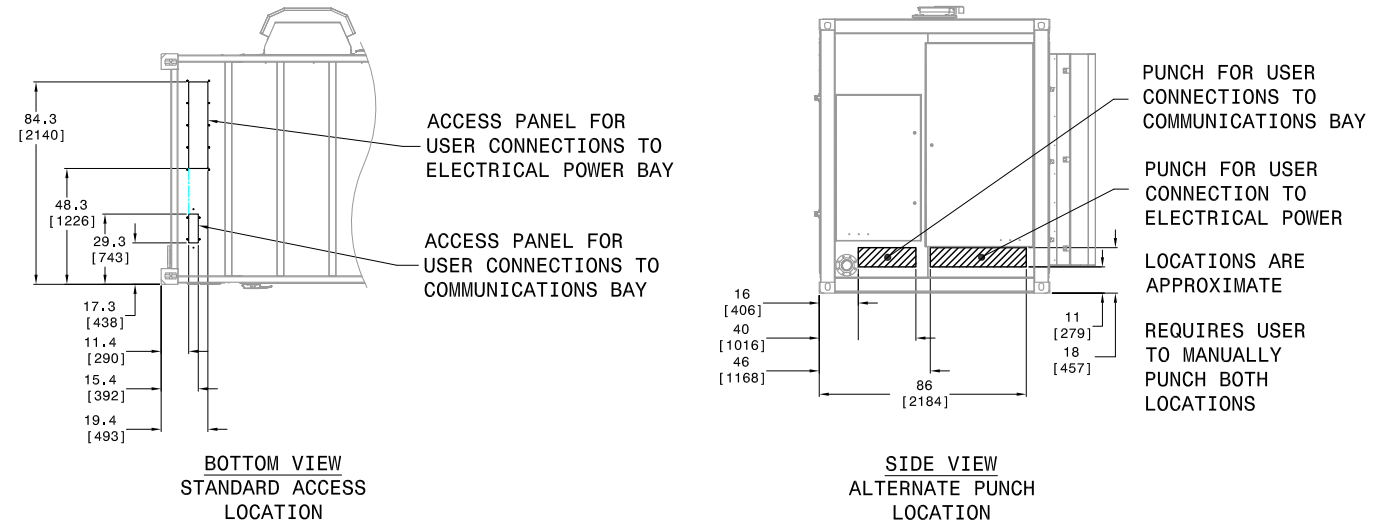

**STANDARD UNIT**

	DUAL MODE					
	C600		C800		C1000	
	HP	LP/LF	HP	LP/LF	HP	LP/LF
CG 'X' IN[MM]	50 [1270]	49 [1245]	50 [1270]	53 [1346]	51 [1295]	50 [1270]
CG 'Y' IN[MM]	183 [4650]	185 [4700]	185 [4700]	185 [4700]	186 [4725]	187 [4750]
CG 'Z' IN[MM]	52 [1321]	51 [1295]	51 [1295]	56 [1423]	50 [1270]	49 [1245]

ELECTRICAL CONNECTIONS		
	WIRE	TORQUE
HIGH POWER	MCM-AWG 600 - MAX	500 IN - LBS
	mm <sup>2</sup> 300 - MAX	5.77 KG - M
NEUTRAL TO GROUND		500 IN - LBS
		5.77 KG-M

	GRID CONNECT					
	C600		C800		C1000	
	HP	LP/LF	HP	LP/LF	HP	LP/LF
CG 'X' IN[MM]	52 [1321]	51 [1295]	52 [1321]	55 [1397]	54 [1372]	52 [1321]
CG 'Y' IN[MM]	184 [4670]	185 [4700]	187 [4750]	187 [4750]	187 [4750]	188 [4670]
CG 'Z' IN[MM]	56 [1423]	55 [1397]	55 [1397]	55 [1397]	56 [1423]	54 [1372]

**NO BATTERY CONFIGURATION**

	DUAL MODE					
	C600		C800		C1000	
	HP	LP/LF	HP	LP/LF	HP	LP/LF
CG 'X' IN[MM]	52 [1321]	51 [1295]	53 [1346]	52 [1321]	53 [1346]	52 [1321]
CG 'Y' IN[MM]	184 [4670]	186 [4720]	186 [4720]	187 [4750]	187 [4750]	189 [4800]
CG 'Z' IN[MM]	56 [1423]	54 [1372]	55 [1397]	54 [1372]	55 [1397]	53 [1346]

COPY IS UNCONTROLLED; USER IS RESPONSIBLE TO VERIFY CURRENT REVISION

**NOTICE**

THIS DOCUMENT CONTAINS INFORMATION WHICH IS BOTH CONFIDENTIAL AND PROPRIETARY TO CAPSTONE TURBINE CORP. NEITHER THIS DOCUMENT NOR THE INFORMATION CONTAINED HEREIN SHALL BE COPIED, DISCLOSED TO OTHERS OR USED FOR ANY PURPOSES BEYOND THE SPECIFIC PURPOSE FOR WHICH THIS DOCUMENT WAS DELIVERED WITHOUT THE EXPRESS WRITTEN PERMISSION OF CAPSTONE TURBINE CORPORATION.  
1895 CAPSTONE TURBINE CORPORATION - ALL RIGHTS RESERVED

REVISIONS			
LTR	DESCRIPTION	DATE	APPROVED
	SEE SHEET 1		

**SERVICE CLEARANCES  
TOP VIEW**

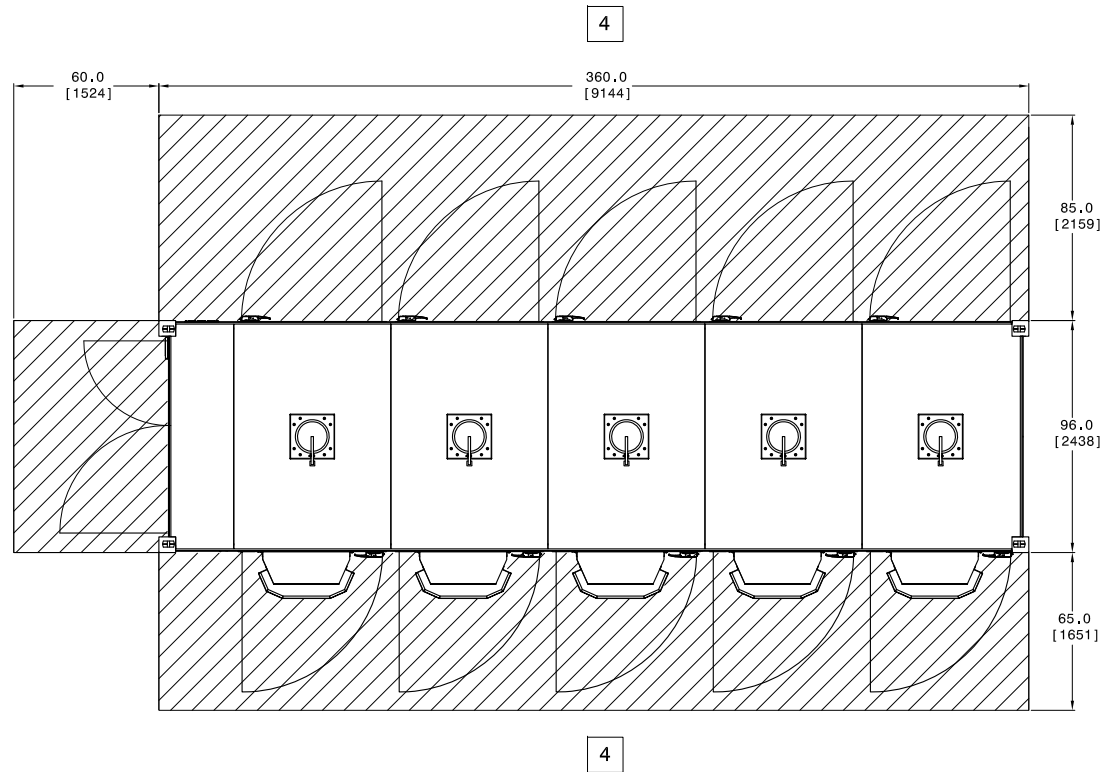

NOTE: ADDITIONAL SERVICE CLEARANCE WILL BE REQUIRED IF USING FORKLIFT, SERVICE CART, ETC DURING MAINTENANCE

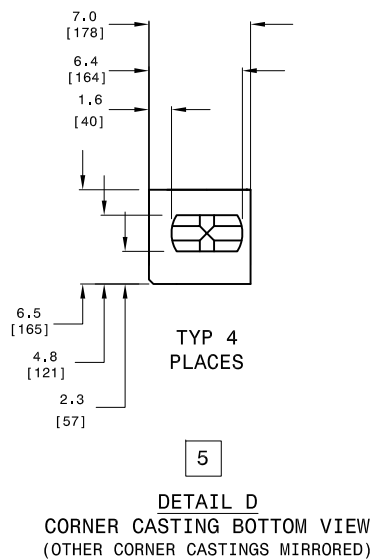

**FOUNDATION DETAILS**

USE CORNER CASTINGS TO SECURE FRAME TO FOUNDATION. SHIM WHERE NEEDED. USE TOE CLAMP TO SECURE FORK POCKETS TO THE FOUNDATION IF SHIMS ARE ADDED BENEATH.

THE FRAME CONTACTS THE FOUNDATION IN SIX (6) PLACES:

FOUR (4) CORNER CASTINGS AND  
TWO (2) FORKLIFT POCKETS

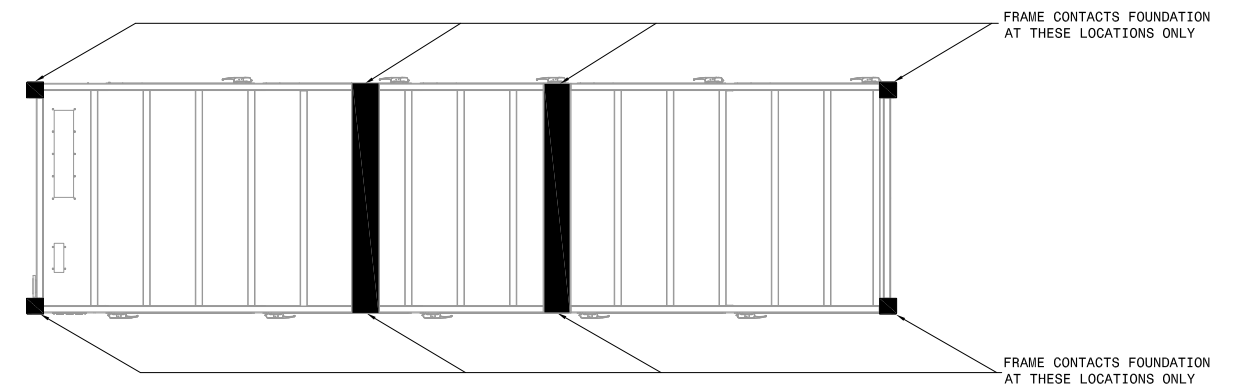

**BOTTOM VIEW  
WEIGHT DISTRIBUTION**

MOUNT FRAME LEVEL WITHIN 2% GRADE. SHIM WHERE NEEDED.

CONCRETE FOUNDATION MUST BE BUILT FLAT TO FF/FL OF FF50/FL33 FOR SPECIFIED OVERALL VALUE AND FF25/FL17 FOR LOCAL MINIMUM VALUE. SEE AMERICAN CONCRETE INSTITUTE'S SPEC ACI 302 FOR FURTHER DETAILS.

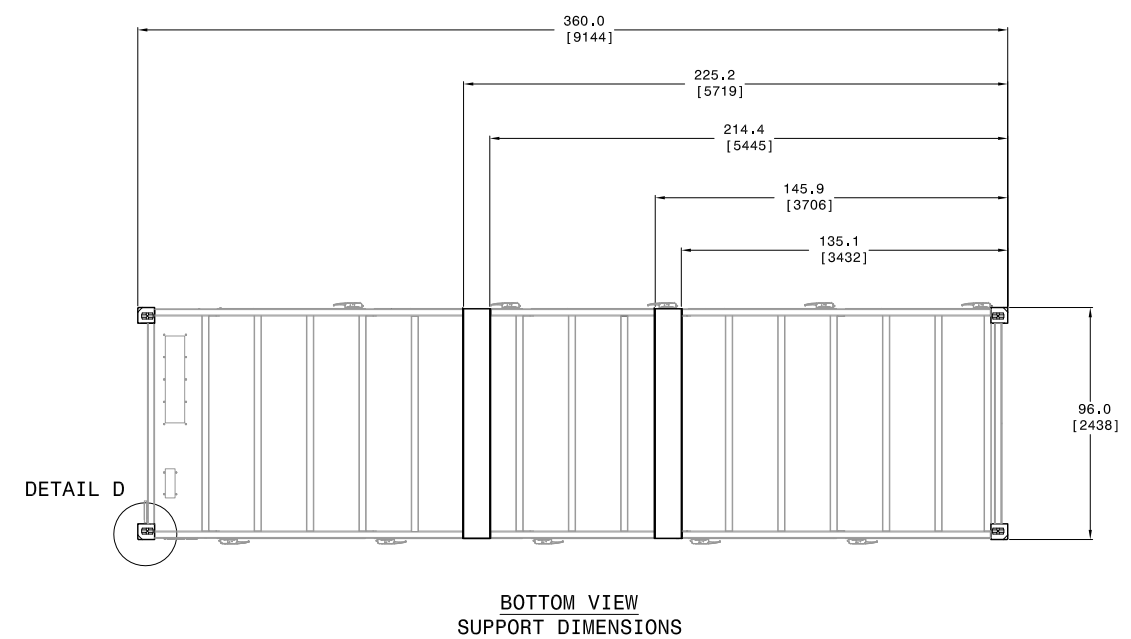

NOTICE

THIS DOCUMENT CONTAINS INFORMATION WHICH IS BOTH CONFIDENTIAL AND PROPRIETARY TO CAPSTONE TURBINE CORP. NEITHER THIS DOCUMENT NOR THE INFORMATION CONTAINED HEREIN SHALL BE COPIED, DISCLOSED TO OTHERS OR USED FOR ANY PURPOSES BEYOND THE SPECIFIC PURPOSE FOR WHICH THIS DOCUMENT WAS DELIVERED WITHOUT THE EXPRESS WRITTEN PERMISSION OF CAPSTONE TURBINE CORPORATION.  
 1885 CAPSTONE TURBINE CORPORATION - ALL RIGHTS RESERVED

REVISIONS			
LTR	DESCRIPTION	DATE	APPROVED

EXAMPLE LIFTING METHODS 7 8 9 15

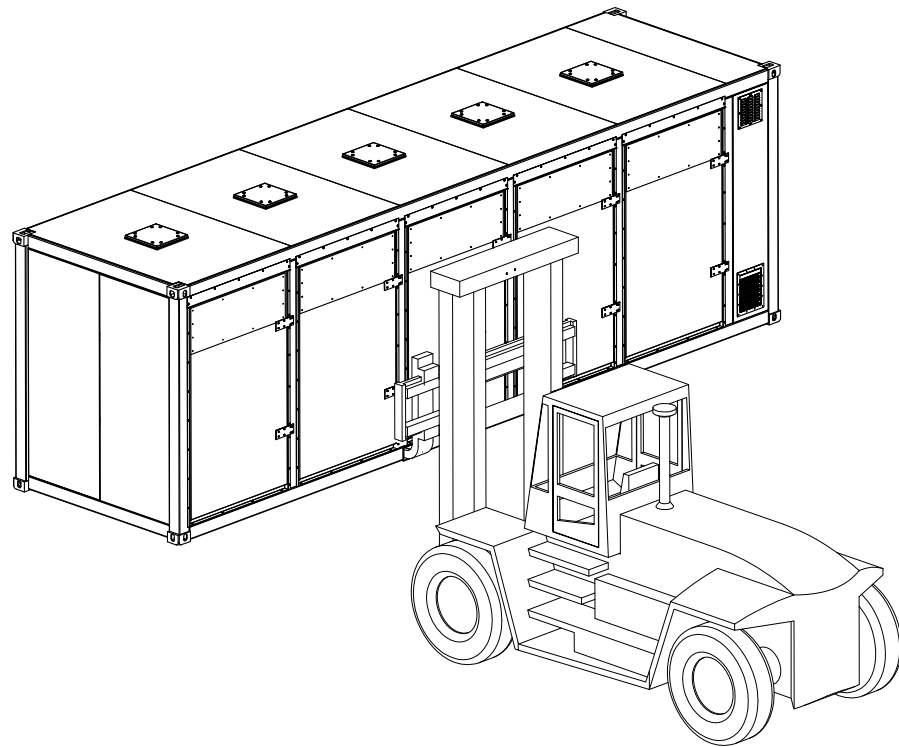

BOTTOM LIFT VIA PROPERLY RATED FORKLIFT

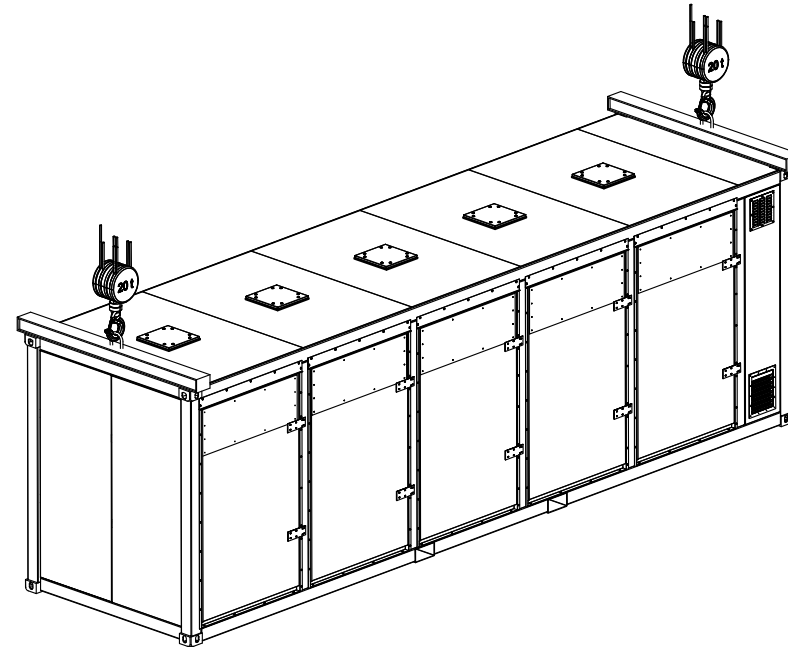

FOUR CORNER TOP LIFT VIA PROPERLY RATED GANTRY CRANE

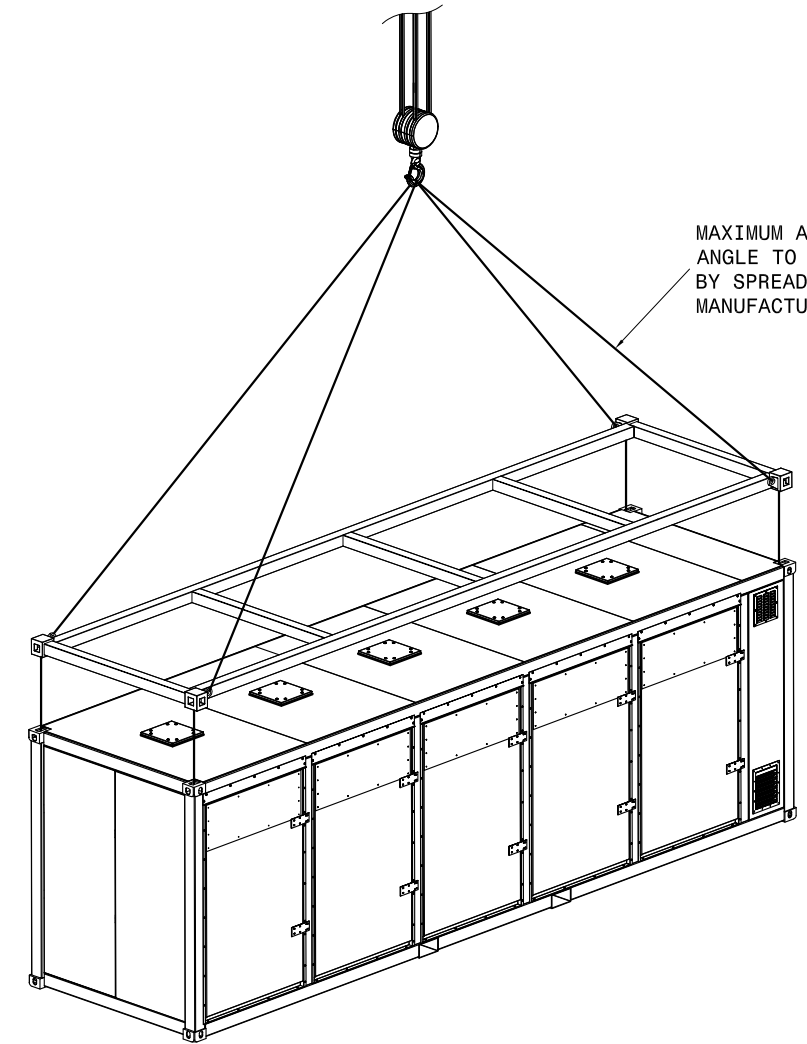

MAXIMUM ALLOWABLE LIFT ANGLE TO BE DETERMINED BY SPREADER BAR MANUFACTURER

FOUR CORNER TOP LIFT VIA PROPERLY RATED SPREADER BARS AND CRANE

DESIGN, CERTIFICATION AND SUPPLY OF THE FORKLIFT, SPREADER BAR/BEAM, I-BEAMS/PIPE, CHAINS OR LIFTING STRAPS BY OTHERS.

COPY IS UNCONTROLLED; USER IS RESPONSIBLE TO VERIFY CURRENT REVISION

DESIGN NO.	534054-001	REV.	C
SHEET 5 OF 6			

REVISIONS			
LTR	DESCRIPTION	DATE	APPROVED
	SEE SHEET 1		

**NOTICE**  
 THIS DOCUMENT CONTAINS INFORMATION WHICH IS BOTH CONFIDENTIAL AND PROPRIETARY TO CAPSTONE TURBINE CORP. NEITHER THIS DOCUMENT NOR THE INFORMATION CONTAINED HEREIN SHALL BE COPIED, DISCLOSED TO OTHERS OR USED FOR ANY PURPOSES BEYOND THE SPECIFIC PURPOSE FOR WHICH THIS DOCUMENT WAS DELIVERED WITHOUT THE EXPRESS WRITTEN PERMISSION OF CAPSTONE TURBINE CORPORATION.  
 1995 CAPSTONE TURBINE CORPORATION - ALL RIGHTS RESERVED

LP = LOW PRESSURE NATURAL GAS  
 LF = LIQUID FUEL  
 HP = HIGH PRESSURE NATURAL GAS, SOUR GAS, DIGEST GAS, LANDFILL GAS & LPG  
 CG = CENTER OF GRAVITY

**C600 COMPARTMENTS ARRANGEMENT**

**C800 COMPARTMENTS ARRANGEMENT**

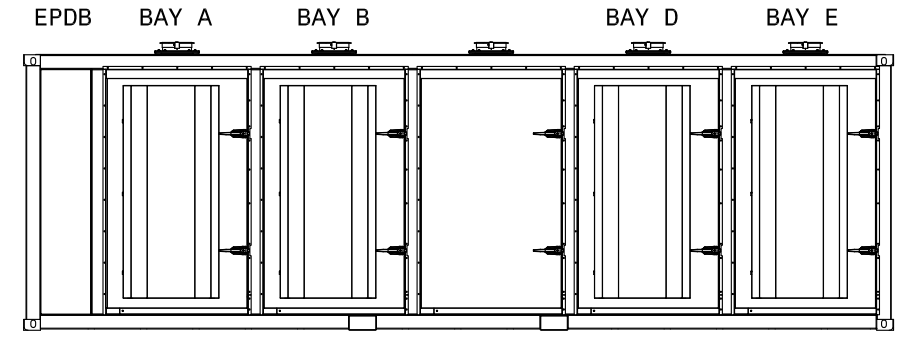
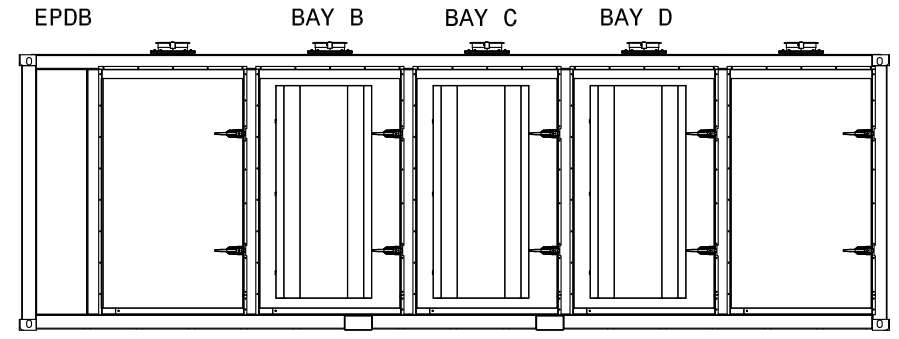

FRONT VIEW

FRONT VIEW

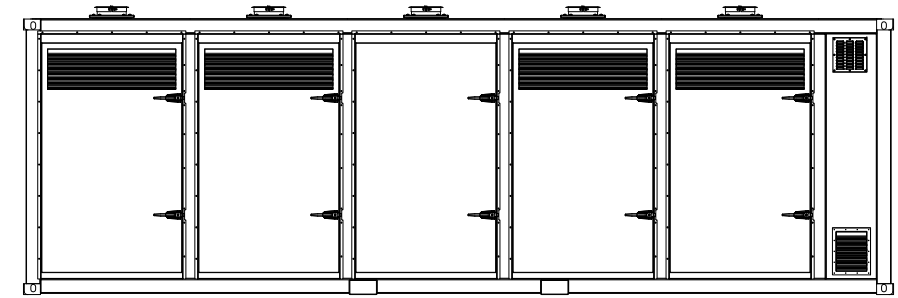
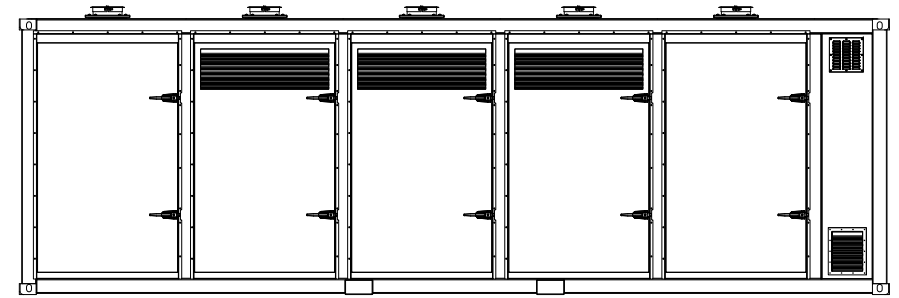

REAR VIEW

REAR VIEW