

**8 NOTICE**

THIS DOCUMENT CONTAINS INFORMATION WHICH IS BOTH CONFIDENTIAL AND PROPRIETARY TO CAPSTONE TURBINE CORP. NEITHER THIS DOCUMENT NOR THE INFORMATION CONTAINED HEREIN SHALL BE COPIED, DISCLOSED TO OTHERS OR USED FOR ANY PURPOSES BEYOND THE SPECIFIC PURPOSE FOR WHICH THIS DOCUMENT WAS DELIVERED WITHOUT THE EXPRESS WRITTEN PERMISSION OF CAPSTONE TURBINE CORPORATION. 1888 CAPSTONE TURBINE CORPORATION - ALL RIGHTS RESERVED

**NOTES**

1 INTERPRET DRAWING PER ASME Y14.5M-1994.

2 ALL DIMENSIONS ARE IN INCHES [MILLIMETERS]

3 ALL DIMENSIONS ARE NOMINAL & ARE TO BE USED AS REFERENCE FOR BUILDING ONLY, UNLESS OTHERWISE SPECIFIED ON THE DRAWING.

4 ALL AROUND CLEARANCES SHOULD BE PROVIDED FOR SERVICE ACCESS. ADDITIONAL SERVICE CLEARANCE WILL BE REQUIRED IF USING A FORKLIFT, SERVICE CART, ETC DURING MAINTENANCE.

5 ISO 1611 COMPATIBLE CORNER FITTINGS.

6 MOUNT LEVEL WITHIN 2% GRADE, SURFACE MUST DRAIN TO PREVENT STANDING WATER. CONCRETE FOUNDATION MUST BE BUILT TO FF/FL OF FF50/FL33 FOR SPECIFIED OVERALL VALUE AND FF25/FL17 FOR LOCAL MINIMUM VALUE. SEE ACI SPEC ACI 302 FOR FURTHER DETAILS.

7 FORKLIFT, SPREADER BARS, ETC., MAY BE USED FOR LIFTING UNIT FROM EITHER SIDE.

8 PROPER RIGGING TO BE PROVIDED DURING LIFTING FOR STABILITY OF THE UNIT. IF LIFTING AT CORNER CASTINGS, SPREADER BARS ARE REQUIRED. WHEN LIFTED USING FORK POCKETS, SUPPORT MUST BE PROVIDED ALL THE WAY THROUGH.

9 SPREADER BAR/BEAM, I-BEAM/PIPE, CHAINS AND LIFTING DESIGN NOT BY CAPSTONE.

10 REFER TO PRODUCT CATALOG FOR OPTIONAL ACCESSORIES.

11 C1000 CONTROLLER WIRING IS CLASS #2 AND FIELD WIRING TO BE CLASS #1.

12 HIGH POWER USER CONNECTION SUITABLE FOR USE WITH EITHER COPPER OR ALUMINUM CONDUCTORS.

13 BOLD DIMENSIONS INDICATE THE MAXIMUM WIDTH, HEIGHT OR DEPTH.

14 ALL VIEWS SHOW GASEOUS FUEL CONNECTION UNLESS OTHERWISE STATED.

15 INTAKE HOOD MUST BE REMOVED WHEN LIFTING AND TRANSPORTING.

REVISIONS			
LTR	DESCRIPTION	DATE	APPROVED
A	PER ECO 105731	03/06/17	P. BREault

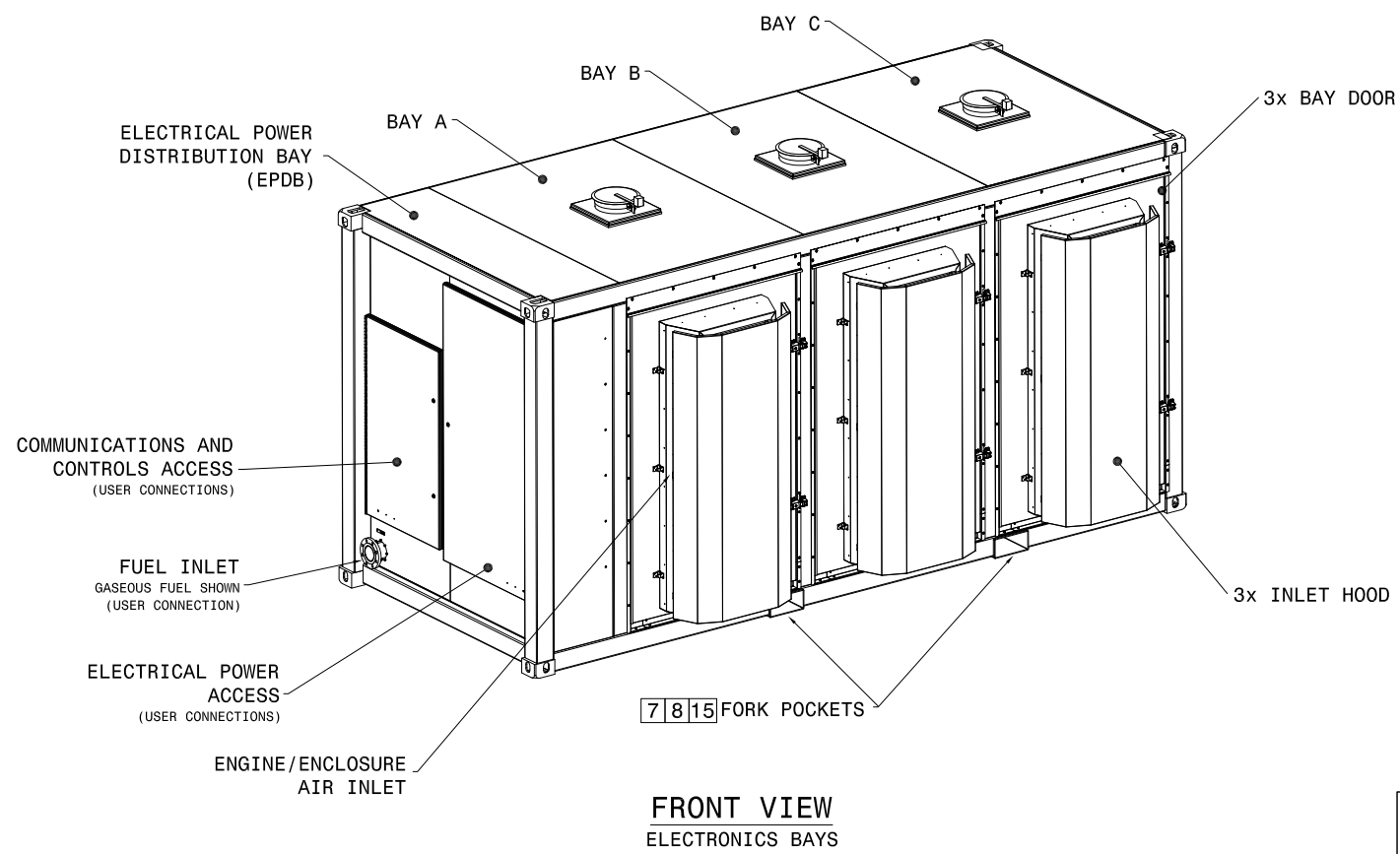
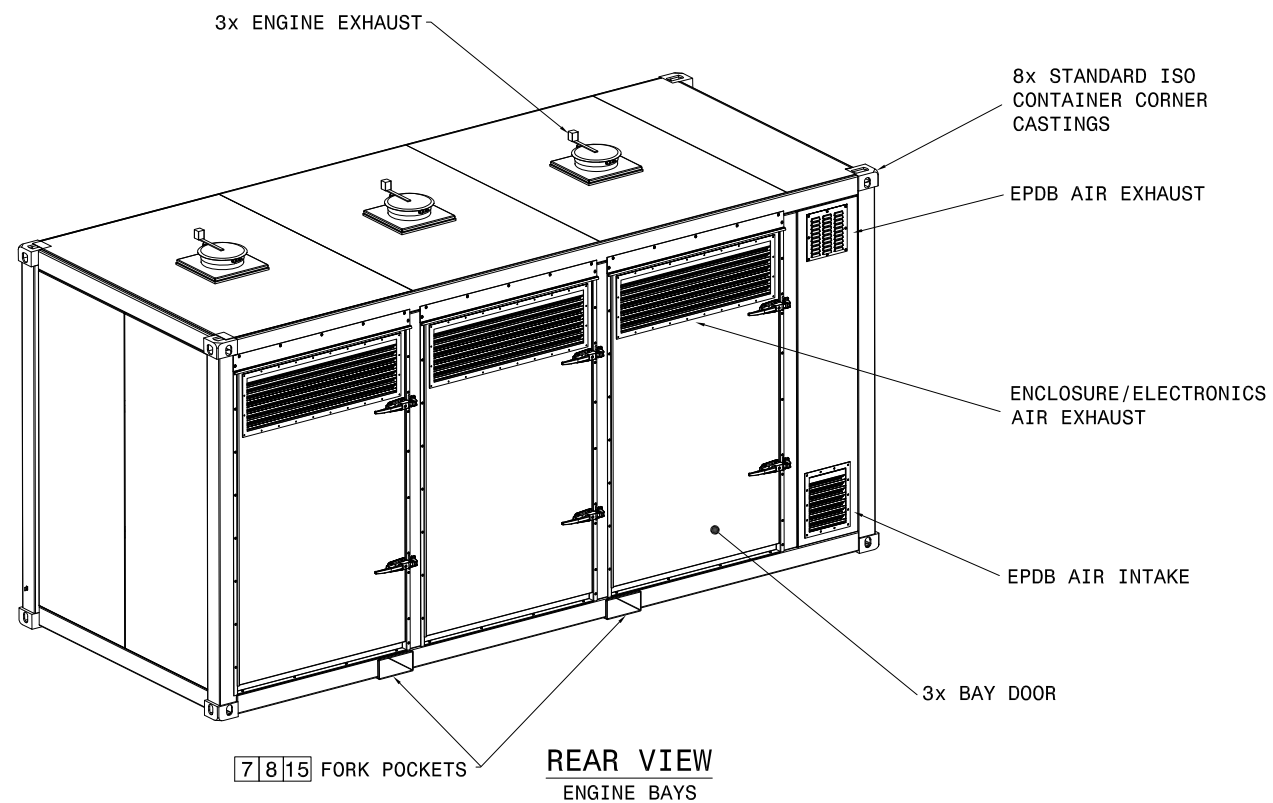

STANDARD WEIGHTS			
HPNG/HPSG	DUAL MODE	29,400 LBS	13,350 KG
LPG/A/B	GRID CONNECT	24,800 LBS	11,250 KG
LPNG/LF	DUAL MODE	31,300 LBS	14,200 KG
	GRID CONNECT	26,600 LBS	12,050 KG

CONFIGURATION MINUS BATTERY WEIGHTS			
HPNG/HPSG	DUAL MODE	25,400 LBS	11,500 KG
LPG/A/B	DUAL MODE	27,100 LBS	12,300 KG

FUELS	FUEL INLET	MODES	
		DM	GC
LPNG	4" FLANGE	X	X
HPNG	4" FLANGE	X	X
LPG	4" FLANGE	X	X
LANDFILL (TYPE A)	4" FLANGE	-	X
DIGESTER (TYPE B)	4" FLANGE	X	X
LIQUID	SEE DETAIL A	X	X

UNLESS OTHERWISE SPECIFIED DIMENSIONS ARE IN INCHES TOLERANCES ARE:	APPROVALS	DATE	2111 HORDOFF STREET DARTMOUTH, GA 31811
DECIMALS .XX ±.02 .XXX ±.010 ANGLES ±.5°	DFTN P. BREault DWRN G. TERZER ENO WDR G. TERZER	03/09/17 03/09/17 03/09/17	
MATERIAL	COB ENO P. BREault	03/09/17	TITLE
FINISH	SEAT ENO		O&I, C600S, IND PKG
DO NOT SCALE DRAWING	THIRD ANGLE PROJECTION		SIZE D SCALE NONE SHEET 1 OF 4

COPY IS UNCONTROLLED; USER IS RESPONSIBLE TO VERIFY CURRENT REVISION

**NOTICE**

THIS DOCUMENT CONTAINS INFORMATION WHICH IS BOTH CONFIDENTIAL AND PROPRIETARY TO CAPSTONE TURBINE CORP. NEITHER THIS DOCUMENT NOR THE INFORMATION CONTAINED HEREIN SHALL BE COPIED, DISCLOSED TO OTHERS OR USED FOR ANY PURPOSES BEYOND THE SPECIFIC PURPOSE FOR WHICH THIS DOCUMENT WAS DELIVERED WITHOUT THE EXPRESS WRITTEN PERMISSION OF CAPSTONE TURBINE CORPORATION.  
 1985 CAPSTONE TURBINE CORPORATION - ALL RIGHTS RESERVED

REVISIONS			
LTR	DESCRIPTION	DATE	APPROVED
	SEE SHEET 1		

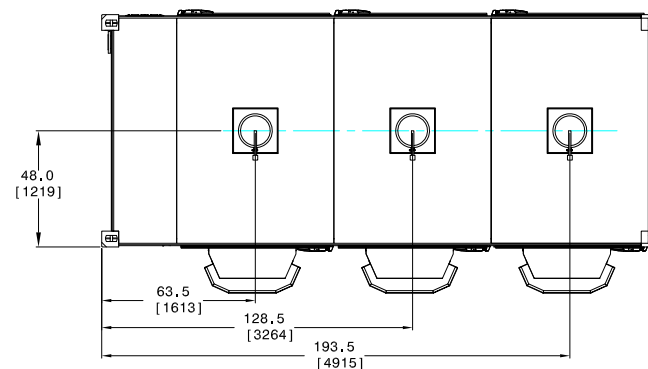

**TOP VIEW**

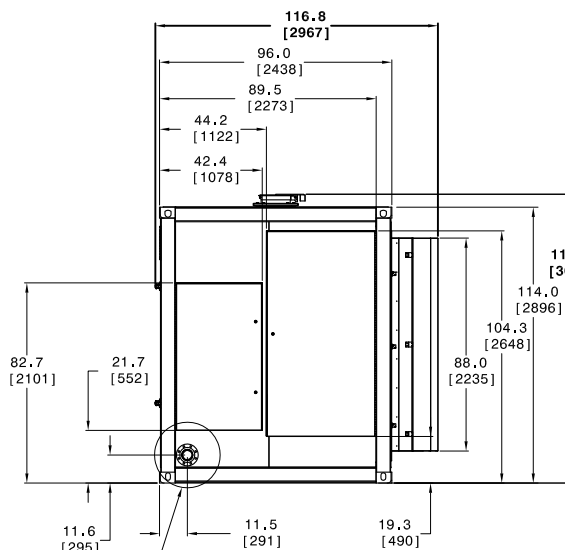

**SIDE VIEW  
CONNECTION BAYS  
(GASEOUS FUEL SHOWN)**

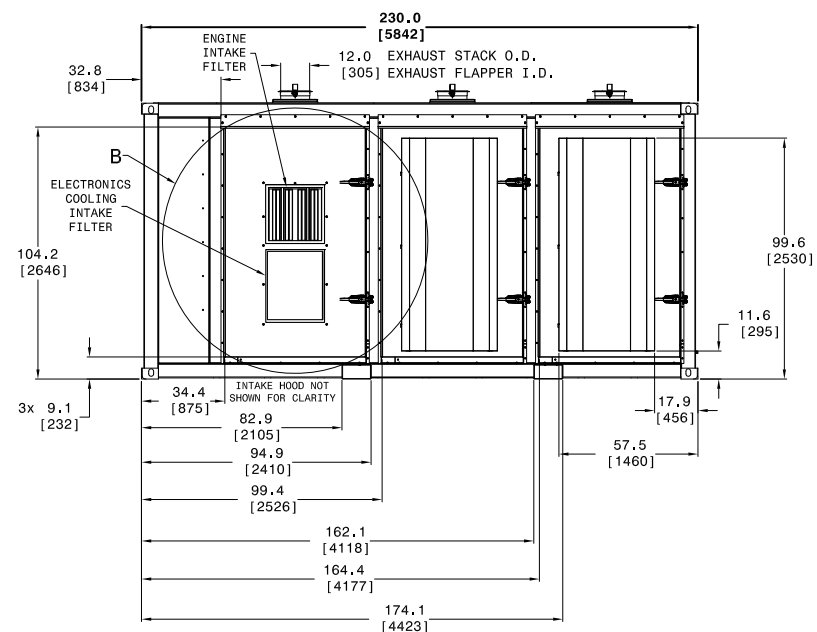

**FRONT VIEW**

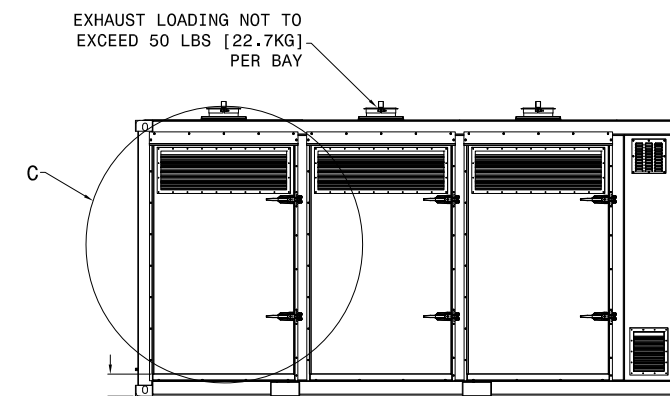

**REAR VIEW**

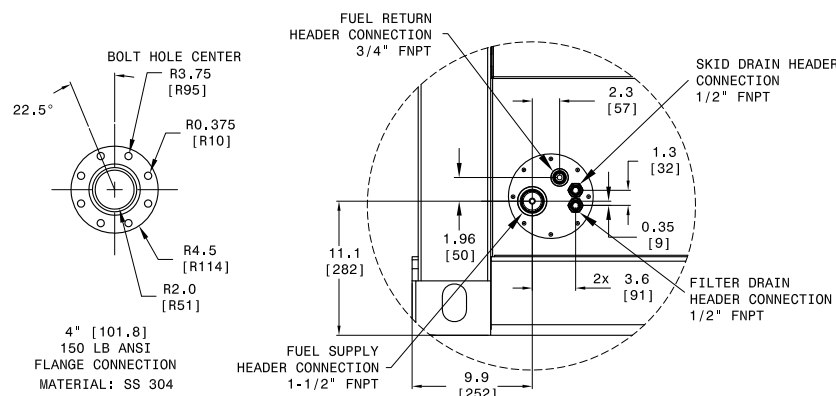

**DETAIL A  
INLET FLANGE**

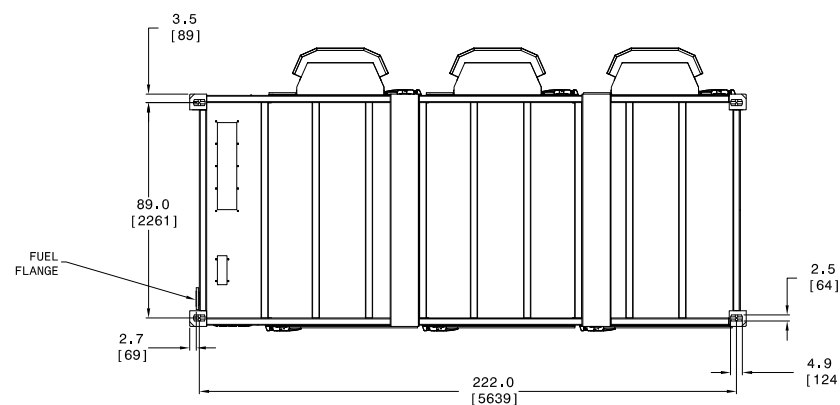

**BOTTOM VIEW**

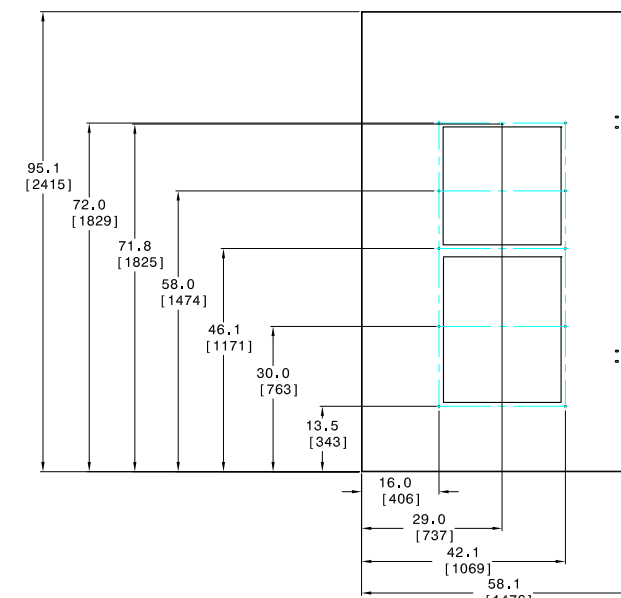

**DETAIL B  
FRONT DOOR  
(SCALE 2:1)**

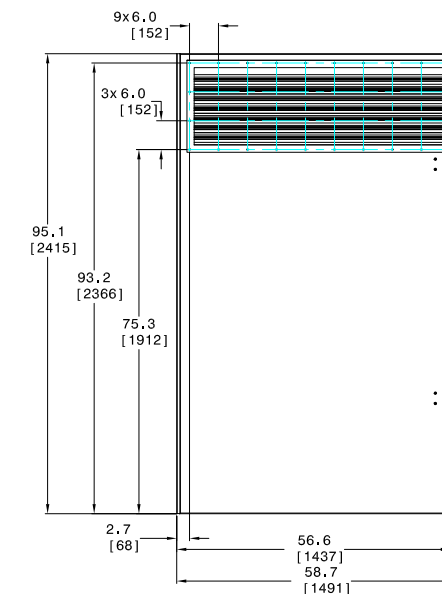

**DETAIL C  
REAR DOOR  
(SCALE 2:1)**

**NOTICE**

THIS DOCUMENT CONTAINS INFORMATION WHICH IS BOTH CONFIDENTIAL AND PROPRIETARY TO CAPSTONE TURBINE CORP. NEITHER THIS DOCUMENT NOR THE INFORMATION CONTAINED HEREIN SHALL BE COPIED, DISCLOSED TO OTHERS OR USED FOR ANY PURPOSES BEYOND THE SPECIFIC PURPOSE FOR WHICH THIS DOCUMENT WAS DELIVERED WITHOUT THE EXPRESS WRITTEN PERMISSION OF CAPSTONE TURBINE CORPORATION.  
 1995 CAPSTONE TURBINE CORPORATION - ALL RIGHTS RESERVED

REVISIONS			
LTR	DESCRIPTION	DATE	APPROVED
	SEE SHEET 1		

**SERVICE CLEARANCES**

TOP VIEW

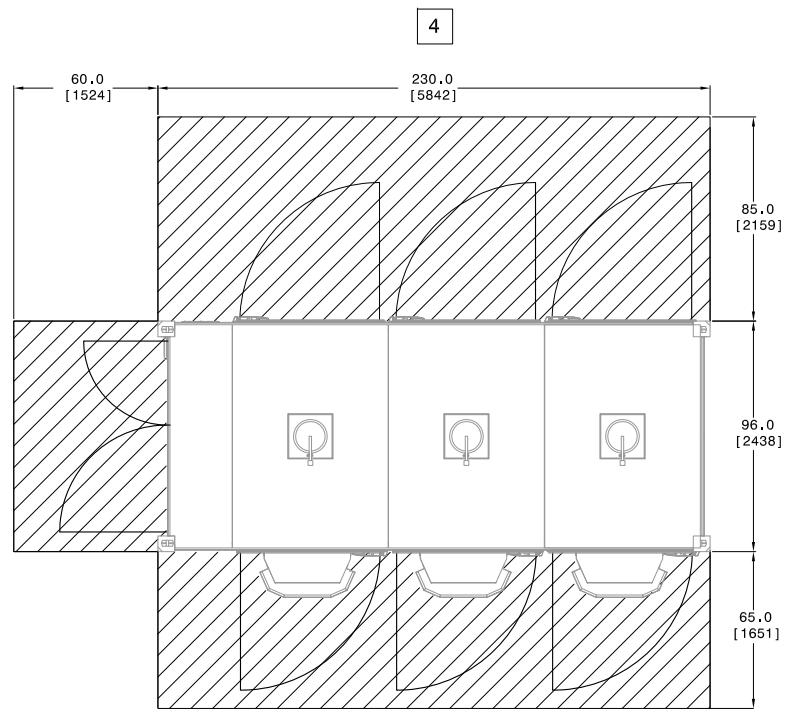

NOTE: ADDITIONAL SERVICE CLEARANCE WILL BE REQUIRED IF USING FORKLIFT, SERVICE CART, ETC DURING MAINTENANCE

**ELECTRICAL CONNECTION ACCESS**

USER CONNECTION ACCESS PANELS

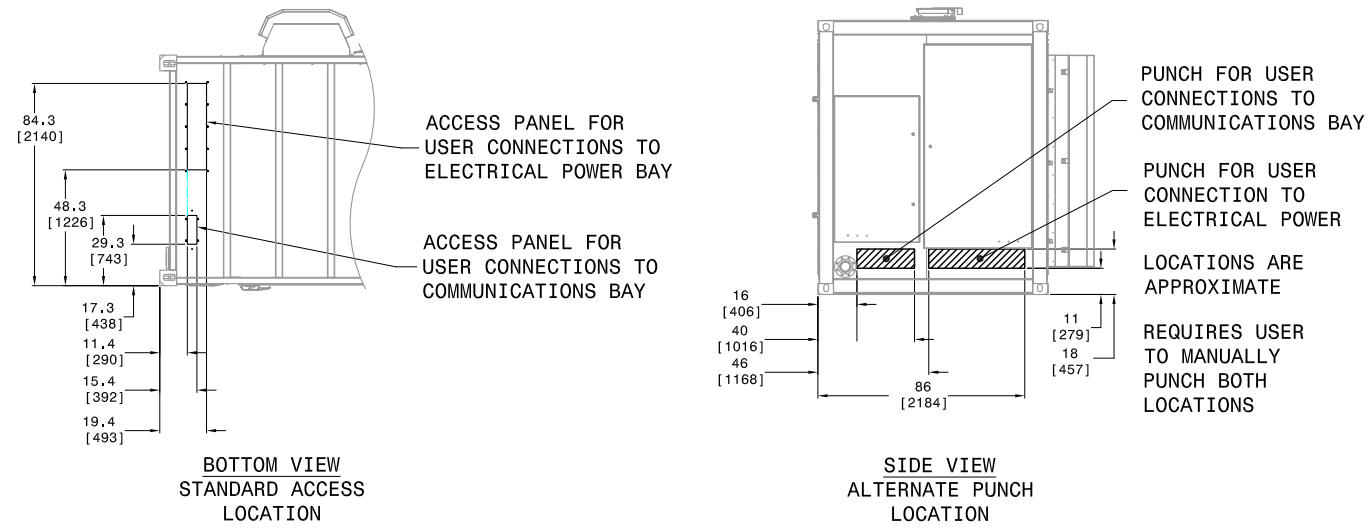

ELECTRICAL CONNECTIONS		
	WIRE	TORQUE
HIGH POWER	MCM-AWG 600 - MAX	500 IN - LBS
	mm <sup>2</sup> 300 - MAX	5.77 KG - M
	NEUTRAL TO GROUND	500 IN - LBS
		5.77 KG-M

**FOUNDATION DETAILS**

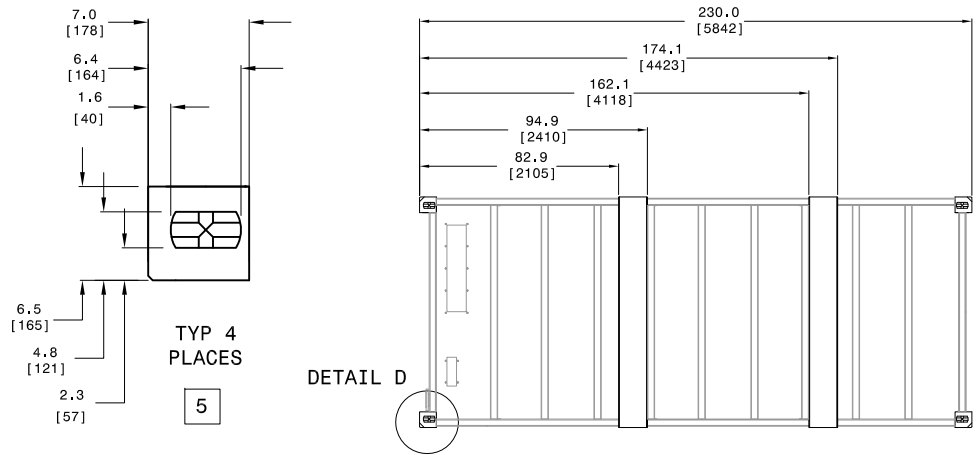

USE CORNER CASTINGS TO SECURE FRAME TO FOUNDATION. SHIM WHERE NEEDED. USE TOE CLAMP TO SECURE FORK POCKETS TO THE FOUNDATION IF SHIMS ARE ADDED BENEATH.

THE FRAME CONTACTS THE FOUNDATION IN SIX (6) PLACES:

- FOUR (4) CORNER CASTINGS AND
- TWO (2) FORKLIFT POCKETS

MOUNT FRAME LEVEL WITHIN 2% GRADE. SHIM WHERE NEEDED.

CONCRETE FOUNDATION MUST BE BUILT FLAT TO FF/FL OF FF50/FL33 FOR SPECIFIED OVERALL VALUE AND FF25/FL17 FOR LOCAL MINIMUM VALUE. SEE AMERICAN CONCRETE INSTITUTE'S SPEC ACI 302 FOR FURTHER DETAILS.

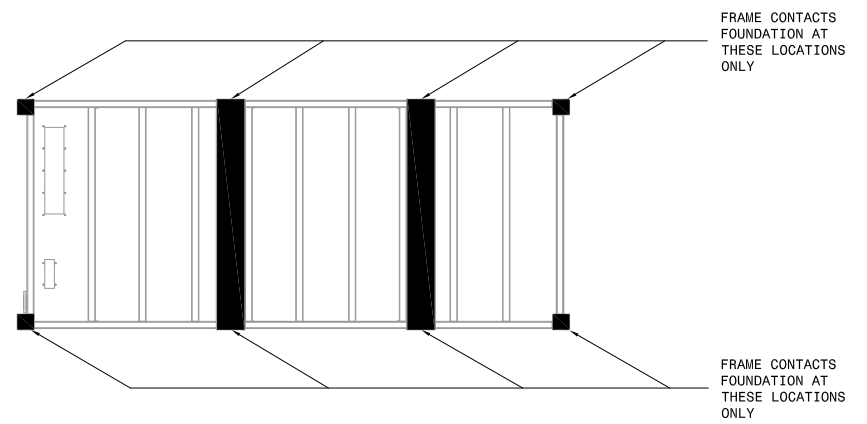

THIS DOCUMENT CONTAINS INFORMATION WHICH IS BOTH CONFIDENTIAL AND PROPRIETARY TO GAPSTONE TURBINE CORP. NEITHER THIS DOCUMENT NOR THE INFORMATION CONTAINED HEREIN SHALL BE COPIED, DISCLOSED FOR WHICH THIS DOCUMENT WAS DELIVERED WITHOUT THE EXPRESS WRITTEN PERMISSION OF GAPSTONE TURBINE CORPORATION.

REVISIONS			
LTR	DESCRIPTION	DATE	APPROVED

### CENTER OF GRAVITY

C600S CENTER OF GRAVITY (COG)				
		COG 'X' IN [MM]	COG 'Y' IN [MM]	COG 'Z' IN [MM]
DUAL MODE	HP	50 [1270]	121 [3075]	50 [1270]
	LP/LF	50 [1270]	122 [3100]	49 [1245]
DUAL MODE NO BATTERY	HP	53 [1350]	123 [3125]	55 [1400]
	LP/LF	52 [1320]	124 [3150]	53 [1350]
GRID CONNECT	HP	52 [1320]	122 [3100]	56 [1425]
	LP/LF	52 [1320]	124 [3150]	54 [1375]

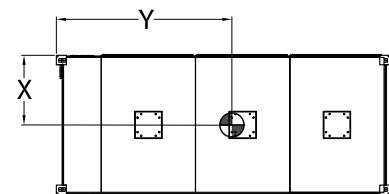

TOP VIEW  
DO NOT SCALE THIS VIEW

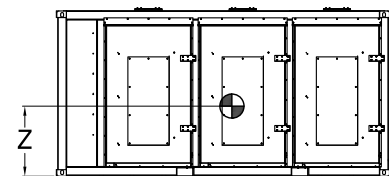

FRONT VIEW  
DO NOT SCALE THIS VIEW

### SHIPPING/LIFTING CONFIGURATION

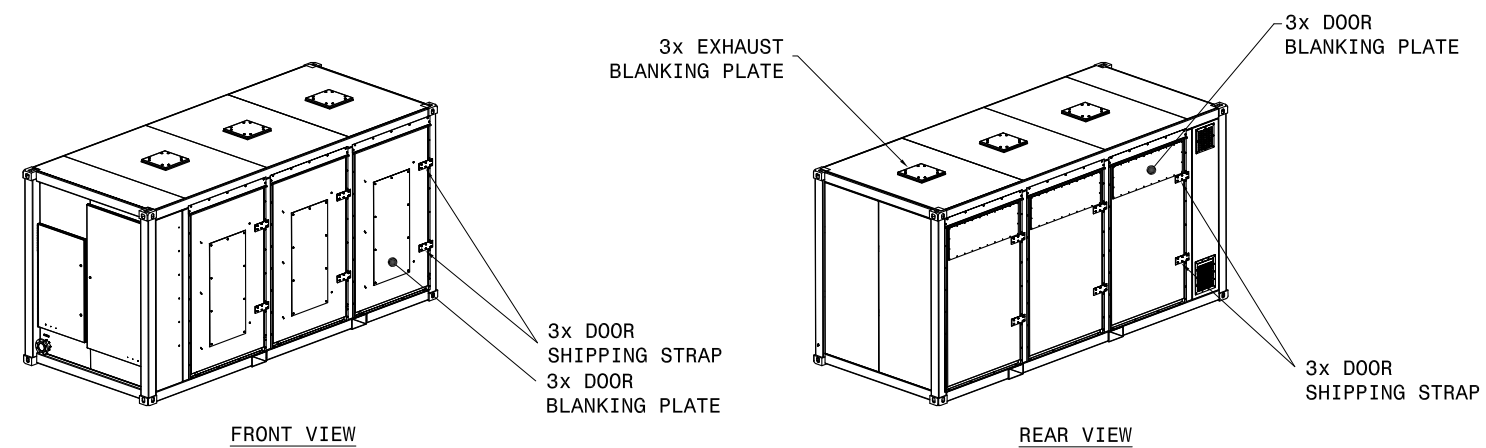

### EXAMPLE LIFTING METHODS 7 8 9 15

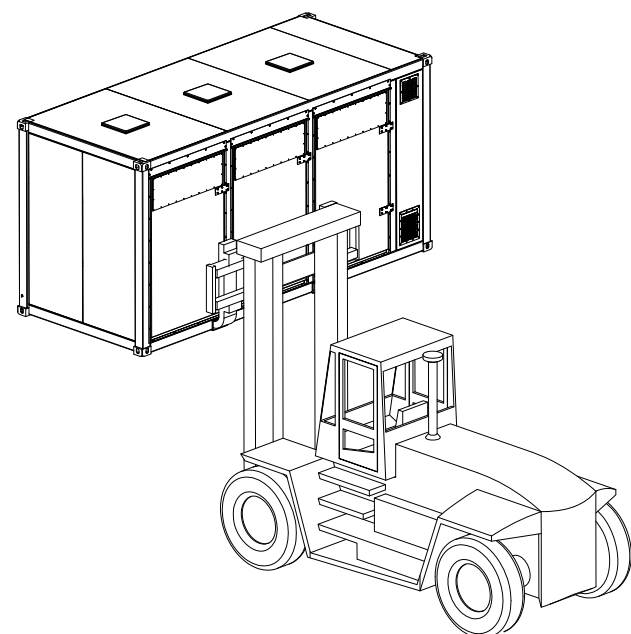

BOTTOM LIFT VIA PROPERLY RATED FORKLIFT

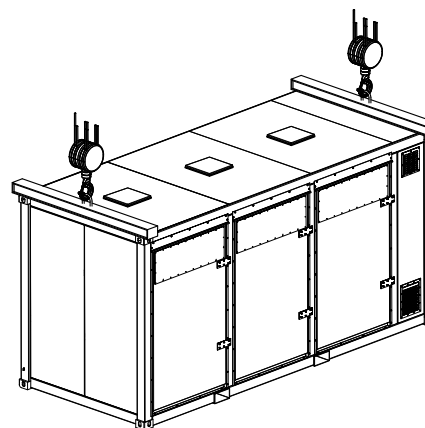

FOUR CORNER TOP LIFT VIA PROPERLY RATED GANTRY CRANE

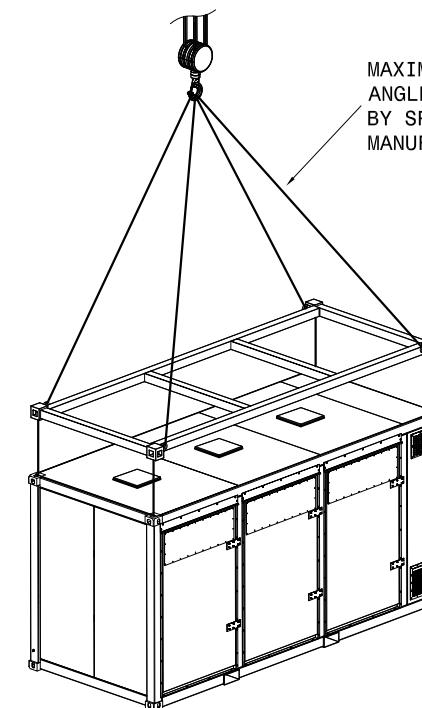

FOUR CORNER TOP LIFT VIA PROPERLY RATED SPREADER BARS AND CRANE

DESIGN, CERTIFICATION AND SUPPLY OF THE FORKLIFT, SPREADER BAR/BEAM, I-BEAMS/PIPE, CHAINS OR LIFTING STRAPS BY OTHERS.

COPY IS UNCONTROLLED; USER IS RESPONSIBLE TO VERIFY CURRENT REVISION

DWG NO.	534788-001	REV.	A
SHEET 4 OF 4			